

GEYA® 格亚电气

GYCM8EY3系列

智能塑壳断路器

Intelligent molded case circuit breaker

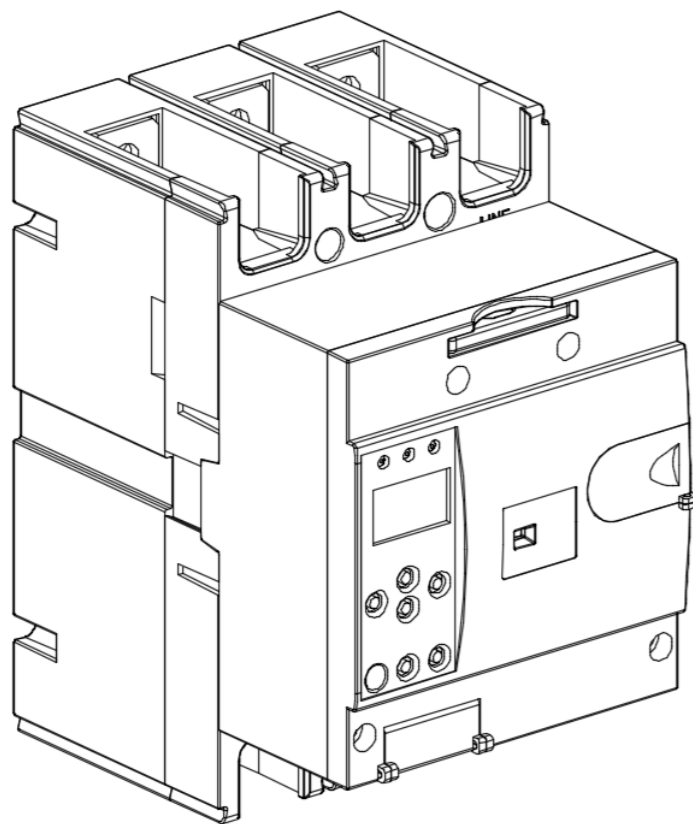

只允许专业人员或受过专业
训练的人员进行下列工作

Only skilled or instructed persons may carry
out the following operations



危险触电
Electric Current!
Danger to life!



产品用途 Application

GYCM8EY3智能型塑壳断路器的额定绝缘电压为1000V, 适用于交流50/60Hz, 额定电压三相AC380V, 额定电流至800A的配电网中。在正常情况下, 断路器可分别作为线路的不频繁转换及电动机的不频繁启动之用。保护线路的过载和短路; 对线路的过压、欠压、缺相、过频、欠频、电压不平衡、电流不平衡、光伏防孤岛具有保护功能; 可测量线路中电流、电压、频率等信息; 具有四遥功能, 通过上位机软件进行遥测、遥信、遥控、遥调。

GYCM8EY3 intelligent molded case circuit breaker has a rated insulation voltage of 1000V and is suitable for AC 50/60Hz, rated voltage of three-phase AC380V, rated current up to 800A in the power distribution network. Under normal conditions, the circuit breaker can be used for infrequent conversion of lines and infrequent starting of motors respectively. It protects the overload and short circuit of the line; it has the protection function for the over-voltage, under-voltage, phase-loss, over-frequency, under-frequency, voltage imbalance, current imbalance, and photovoltaic anti-islanding of the line; it can measure the information of the current, voltage and frequency in the line; and it has the four-remote function, which is telemetry, telemessage, remote-control, and remote-adjustment through the software of the upper computer.

产品符合以下标准:
GB/T 14048.2-2020 低压开关设备和控制设备;
GB/T 22710-2008 低压断路器用电子式控制器。

The product complies with the following standards:
GB/T 14048.2-2020 Low-voltage switchgear and control equipment
GB/T 22710-2008 Electronic controller for low voltage circuit breaker

工作环境 Working environment

- 一、环境温度在-5~+40°C之间, 海拔高度不超过2000米。
- 二、大气条件: 最高温度为40°C, 空气的相对湿度不超过50%, 在较低的温度下可以允许有较高的相对湿度, 例如20°C时达90%。对由于温度变化偶尔产生的凝露应采取特殊的措施。
- 三、安装场所的外磁场在任何方向不超过地磁场的5倍, 产品附近尽量避免大的电磁干扰(如大功率电动机或变频器), 无爆炸性、腐蚀性气体, 无雨雪侵袭, 干燥、通风。
- 四、污染等级: 3级; 安装类别: III

- 1.The ambient temperature is between -5 and +40°C, and the altitude does not exceed 2000 meters.
- 2.Atmospheric conditions: maximum temperature of 40 °C, the relative humidity of the air does not exceed 50%, at lower temperatures can be allowed to have a higher relative humidity, such as 20 °C when up to 90%. Special measures should be taken for occasional condensation due to temperature changes.
- 3.The external magnetic field of the installation place is not more than 5 times of the geomagnetic field in any direction, and large electromagnetic interference (such as high-power motors or frequency converters) should be avoided as much as possible near the product, no explosive or corrosive gases, no rain or snow intrusion, and dry and ventilated.
- 4.Installation category: III.

➤ 符号说明 Symbol Explanation

符号 Symbol	说明 Explanation
Imn	控制器壳架电流 Controller Shell Frame Current
In	控制器额定电流 Rated current of controller
IR	过载长延时脱扣整定电流 Overload long delay tripping setting current
TR	过载长延时整定时间 Overload long delay setting time
I _{sd}	短路短延时脱扣整定电流 Short-circuit short-delay setting current
T _{sd}	短路短延时整定时间 Short-circuit short-delay setting time
I _i	短路瞬时脱扣整定电流 Short-circuit instantaneous tripping setting current
U _{vo}	过电压保护动作值 Overvoltage protection action value
T _{vo}	过电压保护动作延 Overvoltage protection action delay value
U _{vor}	过电压保护不动作返回值 Overvoltage protection non-action return value
U _{vu}	欠电压保护动作值 Undervoltage protection action value
T _{vu}	欠电压保护动作延时值 Undervoltage protection action delay value
U _{zur}	欠电压保护不动作返回值 Undervoltage protection inoperative return value
I	主回路电流 Main circuit current

产品型号参数 Symbol Explanation

电子式液晶型塑壳断路器 Electronic liquid crystal type molded case circuit breaker	GYCM8EY3-250	GYCM8EY3-400	GYCM8EY3-630	GYCM8EY3-800
壳架等级电流 I _n Shell frame rating current I _n	50A-125A 100A-250A	160A-400A	250A-630A	630A(250A-630A) 800A(320A-800A)
短路分断能力代号 Short circuit breaking capacity designator	M H	M H	M H	M H
极数 Poles	3P	3P	3P	3P
额定工作电压 U _e (V), AC Rated operating voltage U _e (V), AC	AC400V	AC400V	AC400V	AC400V
额定绝缘电压 U _i (V) Rated insulation voltage U _i (V)	1000V	1000V	1000V	1000V
额定冲击耐受电压 U _{imp} (kV) Rated impulse withstand voltage U _{imp} (kV)	8kV	8kV	8kV	8kV
额定运行短路分断能力 I _{cs} (kA) Rated operating short-circuit breaking capacity I _{cs} (kA)	AC400V	35kA 65kA	50kA 70kA	50kA 70kA
额定极限短路分断能力 I _{cu} (kA) Rated ultimate short-circuit breaking capacity I _{cu} (kA)		50kA 65kA	50kA 70kA	50kA 85kA
额定短时耐受电流 I _{cw} (kA) Rated short-time withstand current I _{cw} (kA)	10kA/1s	10kA/1s	10kA/1s	20kA/1s
选择性类别 Selective categories	B类 Class B	B类 Class B	B类 Class B	B类 Class B
过电流脱扣器类型 Overcurrent striker type	电子式 Electronic	电子式 Electronic	电子式 Electronic	电子式 Electronic

➤ 产品功能描述 Product function description

智能保护控制器特性功能表
Intelligent Protection Controller Characteristics Function Table

表1: 产品特性功能表
Table 1: Product Characteristics Functional Table

说明: 符号“●”表示有其功能; 符号“○”表示此功能可选择。
Note: The symbol “●” indicates that the function is available;
the symbol “○” indicates that the function is optional.

规格与功能 Specifications & Features		
分类 Categorization	描述 Descriptions	
显示方式 Display Mode	液晶显示+LED指示灯 LCD display + LED indicator	●
界面操作 Interface operation	按键 Buttons	●
测量功能 Measurement function	三相电流 Three-phase current	●
	三相电压 Three-phase voltage	●
	电压频率 Voltage frequency	●
	三相电压不平衡度 Three-phase voltage unbalance	●
	三相电流不平衡度 Three-phase current unbalance	●
	保护功能 Protection function	电流保护 Current protection
过载长延时保护 Overload long delay protection		●
短路短延时保护 Short-circuit short-delay protection		●
短路瞬时保护 Short-circuit instantaneous protection		●
三相电流不平衡 Three-phase current imbalance		●
电压保护 Voltage protection		●
欠、过压保护功能 Under and over voltage protection function		●
缺相保护功能 Phase loss protection function		●
三相电压不平衡 Three-phase voltage imbalance		●
电压欠、过频保护功能 Voltage under- and over-frequency protection		●
通信功能 Communication Functions		○
DL/T 645-2007多功能电表通信协议 DL/T 645-2007 Multifunction Meter Communication Protocol		○
Modbus-RTU通信协议 Modbus-RTU communication protocol		●
通信硬件1路RS-485 Communication hardware 1 RS-485		●
一路无源/有源费控输入 One passive/active charge control input	○	
二路无源触点硬遥控 Two passive contacts hard remote control	●	
事件记录 Event logging	●	
10次跳闸故障存储 10 trip fault storage	●	
30日电压、电流最大/小值记录 30 days of voltage, current maximum / minimum value records	●	
80次保护功能投退事件记录 80 times of protection function put in and out event record	●	
10次闸位变化事件记录 10 times gate level change event record	●	
10次告警事件记录 10 times alarm event record	●	
10次高压失复电记录 10 times of high voltage loss and restoration records	●	
时间功能 Time function	●	
具有年月日时分秒实时时钟功能 With year, month, day, hour, minute and second real-time clock function	●	
温度保护 Temperature protection	○	
3路或4路主线温度加PCB板上温度 3-channel or 4-channel main line temperature plus PCB board temperature	○	

► 保护功能 protection function

电压保护功能 Voltage protection function

1.过压保护功能

过压保护是针对线路出现过电压状况设计的保护功能，控制器的保护方式可以是脱扣或数据告警。保护特性整定范围、整定值、动作特性及误差范围见表2。

1.Over-voltage protection function

Over-voltage protection is a protection function designed for over-voltage conditions on the line, and the protection mode of the controller can be debounce or data alarm. The setting range of protection characteristics, setting value, action characteristics and error range are shown in Table 2.

表2、过压保护特性

Table 2: Over-voltage protection characteristics

参数设置说明 Parameter setting description	整定范围 Setting range	设定步长 Setting steps	动作特性 Motion characteristics
过压阈值 Overpressure threshold value	425 ~ 500V 425 - 500V	1V 1V	延时动作 Delay action
动作延时 Action delay time	1 ~ 10s (可定制) 1 - 10s (Customizable)	1s 1s	定时限 Timer Limit
工作模式 Working mode	跳闸不告警 + 告警不跳闸 + 不跳闸不告警 Trip without alarm + Alarm without trip + No trip no alarm		
保护误差 Protection accuracy	±1%(电压) ±1%(Voltage)		

2.欠压保护功能

欠压保护是针对线路出现欠电压状况的保护功能，控制器的保护方式可以是脱扣或数据告警。保护特性整定范围、整定值、动作特性及误差范围见表3。

2.Undervoltage protection function

Under-voltage protection is a protection function for the under-voltage condition of the line, and the protection mode of the controller can be debounce or data alarm. The setting range, setting value, action characteristics and error range of the protection characteristics are shown in Table 3.

表3、欠压保护特性

Table 3: Undervoltage protection characteristics

参数设置说明 Parameter setting description	整定范围 Setting range	设定步长 Setting steps	动作特性 Motion characteristics
欠压阈值 Undervoltage threshold Value	300 ~ 360V 300 - 360V	1V 1V	延时动作 Delay action
动作延时 Action delay	1 ~ 10s (可定制) 1 - 10s (Customizable)	1s 1s	定时限 Timer Limit
返回延时 Return delay	1s 1s	-- --	定时限 Timer Limit
工作模式 Working Mode	跳闸不告警 + 告警不跳闸 + 不跳闸不告警 Trip without alarm + Alarm without trip + No trip no alarm		
保护误差 Protection accuracy	±1%(电压) ±1%(Voltage)		

3.缺相保护功能

缺相保护是针对线路出现缺电压状况的保护功能，控制器的保护方式可以是脱扣或数据告警。保护特性整定范围、整定值、动作特性及误差范围见表4。

3.Phase loss protection function

Phase-loss protection is a protection function for the lack of voltage on the line, and the protection mode of the controller can be debounce or data alarm. The setting range, setting value, action characteristics and error range of the protection characteristics are shown in Table 4.

表4、缺相保护特性

Table 4: Phase-loss protection characteristics

参数设置说明 Parameter setting description	整定范围 Setting range	设定步长 Setting steps	动作特性 Motion characteristics
缺相阈值 Phase-loss threshold Value	300 ~ 360V 300 - 360V	1V 1V	≤1.0Uvu,延时动作 ≤1.0Uvu,Delay action
动作延时 Action delay	1 ~ 10s (可定制) 1 - 10s (Customizable)	1s 1s	定时限 Timer Limit
返回延时 Return delay	1s 1s	-- --	定时限 Timer Limit
工作模式 Working Mode	跳闸不告警 + 告警不跳闸 + 不跳闸不告警 Trip without alarm + Alarm without trip + No trip no alarm		
保护误差 Protection accuracy	±1%(电压) ±1%(Voltage)		

电流保护功能 Current protection function

1.过载长延时保护功能

过载长延时采用反时限保护方式，其电流-时间特性曲线如下：

$$t = \left(\frac{2IR}{I}\right)^2 \times TR \quad (t: \text{反时限保护实际动作时间})$$

过载长延时保护电流整定值设定范围IR = (0.4 ~ 1.0) × In; 步长1A。

过载长延时保护动作时间设定范围TR = 30 ~ 99s; 步长1s

过载长延时保护特性见表5。

1.Overload long delay protection function

The long delay time of overload adopts the inverse time limit protection mode, and its current-time characteristic curve is as follows:

$$t = \left(\frac{2IR}{I}\right)^2 \times TR \quad (t: \text{actual action time of inverse time limit protection})$$

Overload long delay protection current setting range IR = (0.4-1.0) × In; step size 1A.

Setting range of overload long delay time protection action time TR = 30 - 99s; step length 1s

The overload long delay protection characteristics are shown in Table 5.

表5：过载长延时保护特性

Table 5: Overload long delay protection characteristics

整定范围 Setting range		动作时间 Action time t	
电流 Current I		动作时间 t	
×IR ×IR	1.05IR 1.05IR	TR TR	≤1.05IR,2h内不动作 ≤1.05IR, No action within 2h
	1.30IR 1.30IR		≥1.3IR,小于1h内动作 ≥1.3IR, action within 1h
	2.0IR 2.0IR		30s ~ 99s,步进1s 30s-99s, step 1s
		±10% ±10%	

2.短路短延时保护功能

短路短延时保护默认采用定时限保护特性。

定时限特性：t = Tsd (Tsd = 0.1 ~ 1.0s)

短延时电流整定值：Isd = (2 ~ 10) * IR; 调整步长1.0IR。

短延时保护特性：I < 0.9Isd, 不动作; I ≥ 1.1Isd, 动作。

短延时保护时间精度：±10%。

2.Short-circuit short-delay protection function

The short-circuit short delay protection adopts the fixed time limit protection characteristic by default.

Fixed-time characteristic: t = Tsd (Tsd = 0.1-1.0s)

Short delay current setting value: Isd = (2 ~ 10)* IR; adjustment step 1.0IR.

Short delay protection characteristic: I < 0.9Isd, no action; I ≥ 1.1Isd, action.

Short delay protection time accuracy: ±10%.

3. 短路瞬时保护功能

瞬时保护指当瞬时短路电流产生时，控制器除自身固有的执行时间外，无任何其他延时的跳闸保护。

瞬时保护整定值： $I_i = (2 \sim 12) \times I_R$ ；调整步长 $1.0I_R$ 。

瞬时保护根据用户需要可选择 $\times I_R$ 或 $\times I_n$ ，产品默认为 $\times I_R$ 。

瞬时保护特性： $I < 0.85I_i$ ，不动作； $I \geq 1.15I_i$ ，动作。

瞬时保护控制器固有动作时间： $< 200\text{ms}$ 。

3.Short-circuit instantaneous protection function

Instantaneous protection means that when instantaneous short-circuit current is generated, the controller does not have any other delay tripping protection except its own inherent execution time.

Instantaneous protection setting value: $I_i = (2-12) \times I_R$; adjustment step $1.0I_R$.

Instantaneous protection according to user needs can choose $\times I_R$ or $\times I_n$, the product default is $\times I_R$.

Instantaneous protection characteristics: $I < 0.85I_i$, no action; $I \geq 1.15I_i$, action.

Instantaneous protection controller inherent action time: $< 200\text{ms}$.

4. 电压测量功能

4.Voltage measurement function

电压测量准确度

Voltage measurement accuracy

电压值 Voltage Value	百分数误差极限(引用误差) Percentage Accuracy Limit (Quoted Accuracy)
$0.7U_n \leq U \leq 1.3U_n$ $0.7U_n \leq U \leq 1.3U_n$	$\pm 0.5\%$ $\pm 0.5\%$
$0.35U_n \leq U < 0.7U_n$ $0.35U_n \leq U < 0.7U_n$	$\pm 1\%$ $\pm 1\%$

5. 电流测量功能

5.Current measurement function

电流测量准确度（三相电压平衡，额定电压）

Current measurement accuracy (three-phase voltage balance, rated voltage)

电流值 Current Value	百分数误差极限(引用误差) Percentage Accuracy Limit (Quoted Accuracy)
$0.004I_n \leq I < 0.05I_n$ $0.004I_n \leq I < 0.05I_n$	$\pm 2\%$ $\pm 2\%$
$0.05I_n \leq I \leq 1.2I_n$ $0.05I_n \leq I \leq 1.2I_n$	$\pm 1\%$ $\pm 1\%$

通信功能 Communication function

1. 通信方式

在通信网络中，本控制器为数据从站设备，可实现预期从主站接收信息并与主站进行信息交换，本控制器的所有数据及告警方式必须由主站查询方式获取，不支持主动向主站发起数据上传功能，除非用户特殊定制说明。

本控制器物理层接口默认为RS-485串行电气接口，支持半双工通信方式。

通信速率设置范围：1200bps、2400bps、4800bps、9600bps、19200bps，默认：9600bps，通讯有效传输距离小于等于1200m。

1.Communication mode

In the communication network, this controller is a data slave device, which can realize expected to receive information from the master station and exchange information with the master station, all the data and alarm mode of this controller must be acquired by the master station query mode, and it does not support the function of actively initiating data uploading to the master station unless the user specially customizes the instructions.

The physical layer interface of this controller is RS-485 serial electrical interface by default, supporting half-duplex communication.

Communication rate setting range: 1200bps, 2400bps, 4800bps, 9600bps, 19200bps, default: 9600bps, the effective transmission distance of communication is less than or equal to 1200m.

2. 通信协议

通信协议支持：

支持Modbus-RTU通信协议；

DL/T 645 低压塑壳断路器通信规约(不同地区使用规约不一定相同，根据客户需要可定制)。

2.Communication protocol

Communication protocol:

Support Modbus-RTU communication protocol;

DL/T 645 low-voltage molded case circuit breaker communication protocol (different regions do not necessarily use the same protocol, customizable according to customer needs).

光伏被动式防孤岛保护 Photovoltaic passive anti-islanding protection

光伏被动式防孤岛保护，主要通过过/欠压保护、过/欠频保护、电压幅值摆动检测等综合判断。

PV passive anti-islanding protection, mainly through over/under-voltage protection, over/under-frequency protection, voltage amplitude swing detection and other comprehensive judgment.

三相电压/电流不平衡 Three-phase voltage/current unbalance

三相不平衡保护是针对电路电压/电流出现三相不平衡等状态设计的保护功能。

Three-phase unbalance protection is a protection function designed for the state of three-phase unbalance of circuit voltage/current.

故障及告警功能 Fault and alarm function

1. 故障记录功能：

具体记录类型参见表1：产品特性功能表。

2. 告警功能：

控制器支持各种具有延时保护功能的故障告警指示及数据记录功能，数据告警功能可通过“功能设置”菜单中的“数据告警”设置项“打开”或“关闭”。（通信规约中，控制字1：Bit6=0全禁止，Bit6=1全允许）

1.Fault record function

For the specific recording type, see Table 1: Product Characteristics Function Table.

2.Alarm Function

The controller supports all kinds of fault alarm indication and data logging function with delay protection function, the data alarm function can be turned on or off through the "Data alarm" setting item in the "Function setting" menu. The data alarm function can be "turned on" or "turned off" by the setting item "Data alarm" in the "Function setting" menu. (In the communication statute, control word 1: Bit6=0 all prohibited, Bit6=1 all permitted.)

实时时钟功能 Real-time clock function

时钟功能

实时时钟包括：YY年、MM月、DD日、hh时、mm分、ss秒。

具有时钟功能的控制器可通过“时间设置”项进行时间日期的修改，也支持通信广播校时对时钟进行设置。

Clock function

Real-time clock includes: YY year, MM month, DD day, hh hour, mm minute, ss second.

Controllers with clock function can modify the time and date through the "Time Setting" item, and also support the communication broadcasting calibration time to set the clock.

► 产品功能设置及使用 Product function setting and use

1. 操作界面

控制器操作界面如图1所示，界面有1个液晶显示窗口、3个LED功能指示灯、6个功能按键组成。

1.Operation interface

The controller operation interface is shown in Figure 1. The interface consists of 1 LCD window, 3 LED function indicators, and 6 function buttons.



图1: 控制器操作界面
Figure 1: Controller operation interface

2.LED指示灯功能定义

电源灯：当开关为合闸状态是指示灯恒亮，分闸状态指示灯熄灭。

故障灯：当开关出现故障报警时指示灯闪亮，闭锁时恒亮。

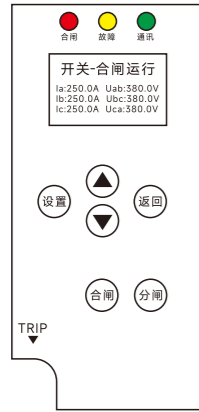
通讯灯：当开关正常运行时指示灯闪亮。

2.LED indicator function definition

Power light: When the switch is in the closed state, the indicator light is always on, and the indicator light is off in the open state.

Fault light: The indicator light flashes when the switch has a fault alarm, and stays on when locked.

Communication light: The indicator light flashes when the switch is operating normally.

3.按键功能定义

向上键：开关在设置状态下，对菜单上翻或数据的加操作。在正常运行状态下按此按键可查看实时电压、电流、三相不平衡率、频率、过载、瞬时、短路档位参数。

向下键：开关在设置状态下，对菜单下翻或数据的减操作。在正常运行状态下按此按键可查看实时电压、电流、三相不平衡率、频率、过载、瞬时、短路档位参数。

设置/确定键：开关在任何状态下，按此按键可进入控制器的主菜单界面。开关在设置状态下，按此按键进行菜单选择进入或设置数据的存储操作；也用于开关在闭锁状态时按此按键解锁返回正常运行状态操作。

返回键：开关在设置状态下，按此按键退出设置菜单操作；也用于数据设置状态时放弃存储操作；也用于子菜单的返回上一级菜单操作。

3.Key function definition

Up key: When the switch is in the setting state, it is used to scroll up the menu or add data. In the normal operating state, press this button to view the real-time voltage, current, three-phase unbalance rate, frequency, overload, instantaneous, and short-circuit gear parameters.

Down key: When the switch is in the setting state, it is used to scroll down the menu or subtract data. In the normal operating state, press this button to view the real-time voltage, current, three-phase unbalance rate, frequency, overload, instantaneous, and short-circuit gear parameters.

Set/Confirm key: When the switch is in any state, press this button to enter the main menu interface of the controller. When the switch is in the setting state, press this button to enter the menu selection or set the data storage operation; it is also used when the switch is in the locked state to press this button to unlock and return to the normal operating state.

Return key: When the switch is in the setting state, press this button to exit the setting menu operation; it is also used to abandon the storage operation in the data setting state; it is also used to return to the previous menu operation of the submenu.

4.按键操作定义

点按：按下某个按键并维持很短时间（小于1s）后释放；

连续点按：连续点按某个按键，间隔时间小于1s。

4.Key operation definition

Tap: Press a key for a short time (less than 1 second) and then release it;

Continuous tap: Press a key continuously with an interval of less than 1 second.

5.界面显示状态

控制器显示状态分为：正常运行状态、报警状态、故障闭锁状态和人机操作状态。

5.Interface display status

The controller display status is divided into: normal operation status, alarm status, fault lockout status and human-machine operation status.

6.正常运行状态

正常运行状态是指控制器在没有故障及报警状态下开关合闸运行时液晶与指示灯的状态内容。在正常运行状态下，液晶显示分3屏，循环显示当前主回路实时电压、电流、三相不平衡率、频率、过载、瞬时、短路档位参数等信息。

图2-a、b、c为正常运行液晶显示界面。

6.Normal operation status

Normal operation state refers to the state of the LCD and indicator lights when the controller is in the state of no fault or alarm. In normal operation state, the LCD display is divided into 3 screens, which cyclically display the current main circuit real-time voltage, current, three-phase imbalance rate, frequency, overload, instantaneous, short circuit gear parameters and other information.

Figure 2-a, b, c are the normal operation LCD display interface.



图2-a
Figure 2-a



图2-b
Figure 2-b

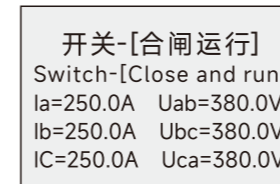

图2-c
Figure 2-c

7.正常运行界面下同时“合闸”指示灯恒亮。

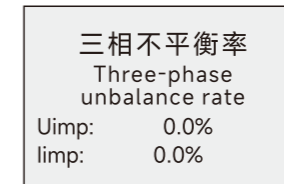
正常运行界面显示说明：

图2-a、当开关为分闸时：开关-[分闸闭锁]，为合闸时：开关-[合闸运行]。

图2-b、显示当前电流不平衡率，电压不平衡率，电压频率。

图2-c、显示当前电流三段保护设置值及实时时钟。

7.In the normal operation interface, the "Close" indicator light is always on.

Normal operation interface display description:

Figure 2-a, when the switch is open: switch-[Open lock], when it is closed: switch-[Close operation].

Figure 2-b, displays the current current unbalance rate, voltage unbalance rate, and voltage frequency.

Figure 2-c, displays the current current three-stage protection setting value and real-time clock.

8.故障闭锁状态界面

故障闭锁界面指开关跳闸后控制器显示的信息界面，如图3所示的几种故障闭锁界面，同时“故障”指示灯恒亮报警。

8.Fault lock status interface

The fault lockout interface refers to the information interface displayed by the controller after the switch trips, such as the several fault lockout interfaces shown in Figure 3. At the same time, the "fault" indicator light is always on to alarm.

图3：故障闭锁界面（反黑显示代表故障相别） Figure 3: Fault lockout interface (black display indicates fault phase)



9.人机操作界面

人机操作界面指在一些设置查询状态下,显示的界面信息。如图4所示几种操作指示状态界面。

9.Human-machine interface

The human-machine operation interface refers to the interface information displayed in some setting query states. Figure 4 shows several operation indication state interfaces.

图4: 操作指示界面 Figure 4: Operation Instructions Interface

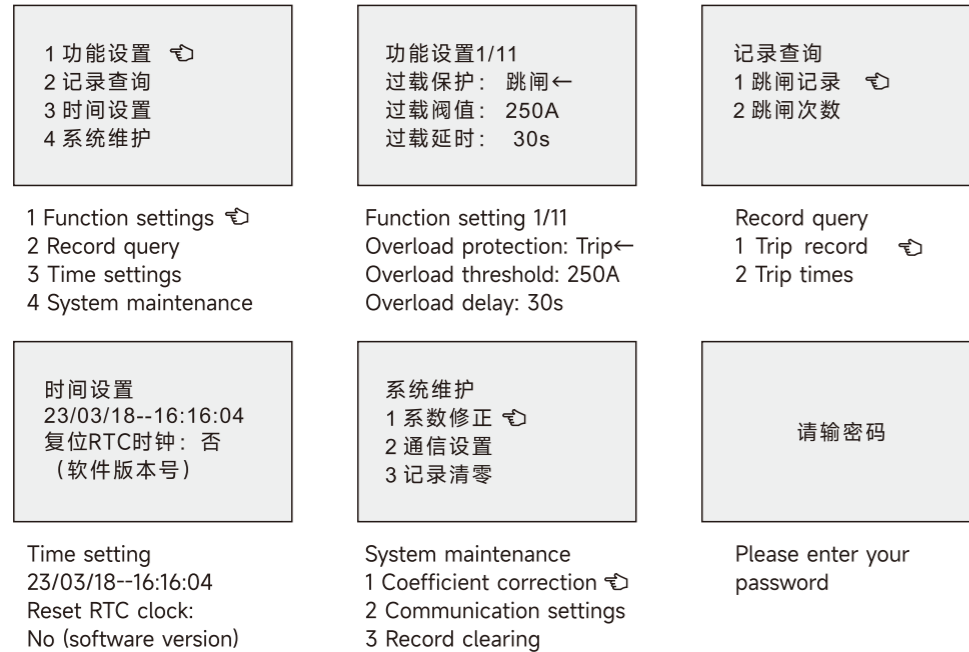

以上操作指示只列举了部分界面,具体请根据不同界面进行相应的操作。

“↵”指示有子菜单数据,“←”指示当前可设置数据选项。

The above operation instructions only list some interfaces. Please perform corresponding operations according to different interfaces.

“↵” indicates that there is submenu data, and “←” indicates that the data options can be set at present.

液晶操作 LCD operation

1.主菜单操作

在开关任何状态下均可按“设置”键,进行参数设置或信息查询等操作,特别提示:在开关闭锁状态下应先确定开关跳闸原因,排除故障后方可按“设置”键进入设置菜单。

操作方法:点按“设置”键,控制器进入设置主菜单,图5所示,然后点按“▲”、“▼”键向上或向下浏览菜单信息,浏览到的当前菜单点按“确定”键可进入对应此项的子菜单。

主菜单包括:1功能设置、2记录查询、3时间设置、4系统维护四项功能菜单。

1.Main menu operation

In any state of the switch, the "Set" button can be pressed to perform parameter settings or information queries. Special reminder: in the locked state of the switch, the reason for the switch tripping should be determined first, and the fault should be eliminated before pressing the "Set" button to enter the setting menu.

Operation method: Click the "Settings" button to enter the main menu of the controller, as shown in Figure 5. Then click the "▲" and "▼" buttons to browse the menu information up or down. Click the "OK" button to enter the corresponding submenu of the current menu.

The main menu includes four functional menus: 1. Function Settings, 2. Record Query, 3. Time Settings, and 4. System Maintenance.



图5
Figure 5

2.功能设置选项

功能“设置菜单1/6”中1表示当前第一屏显示内容,6表示该菜单共有6屏显示内容。

在“功能设置”菜单下点按“向上”或“向下”键浏览参数设置选项,当在“←”指向的参数设置项时,点按“确定”键,该参数可以设置部分出现反黑显示、此时可通过“向上”、“向下”对该参数或功能进行设置,然后通过点按“确定”键对其进行存储或点按“返回”键放弃此次设置。如图6所示步骤操作。

2.Function setting options

In the "Settings Menu 1/6" function, 1 indicates the current first screen display content, and 6 indicates that the menu has a total of 6 screens displaying content.

Under the "Function Settings" menu, click the "Up" or "Down" keys to browse the parameter setting options. When the parameter setting item pointed to by "←" is selected, click the "OK" key. The parameter setting section will appear in black. At this time, you can set the parameter or function by clicking the "Up" or "Down" keys, and then click the "OK" key to store it or click the "Return" key to discard this setting. Follow the steps shown in Figure 6.



图6 Figure 6

功能设置菜单所有参数设置项及设置范围如下表所示:

All parameter settings and their ranges in the function settings menu are shown in the following table:

设置参数菜单 Set parameter menu	设置项 Setting items	参数设置范围 Parameter setting range	出厂默认值 Factory Default
功能设置1/11 Function setting 1/11	过载保护功能 Overload protection function	关闭、告警、跳闸 Close, alarm, trip	跳闸 trip
	过载电流阈值 Overload current threshold	$IR = (0.4 \sim 1.0) \times I_n$, 2倍反时限曲线 $IR=(0.4-1.0) \times I_n$, 2-fold inverse time curve	按In Press in
	过载动作延时 Overload action delay	30 ~ 99s 30 ~ 99s	30s 30s

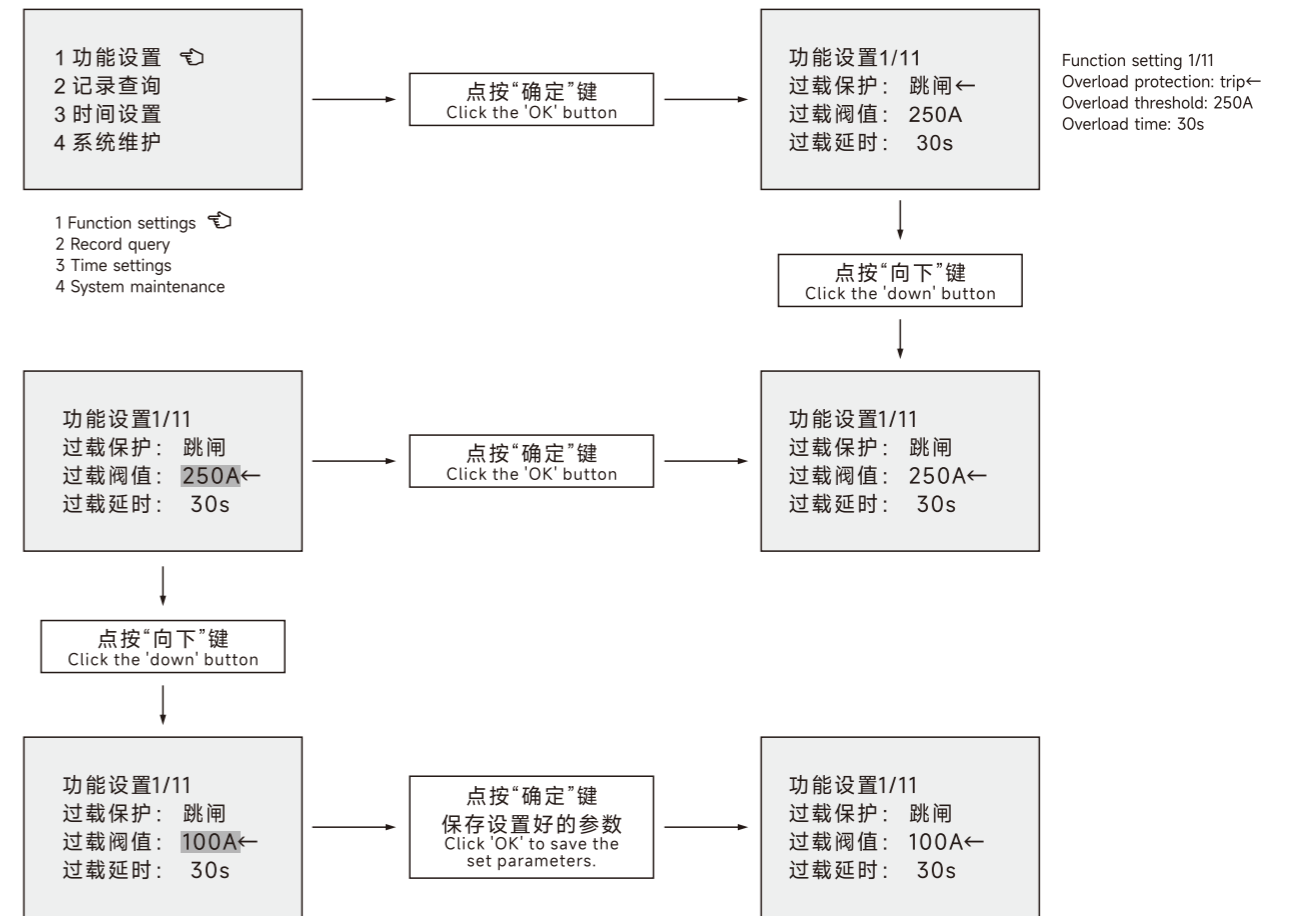
设置参数菜单 Set parameter menu	设置项 Setting items	参数设置范围 Parameter setting range	出厂默认值 Factory Default
功能设置2/11 Function setting 2/11	短路短延时保护 Short circuit short delay protection	关闭、告警、跳闸 Close, alarm, trip	跳闸 trip
	短路短延时阈值 Short circuit short delay threshold	$I_{sd} = (2 \sim 10) \times I_R$ $I_{sd} = (2 \sim 10) \times I_R$	8I _R 8I _R
	短路短延时时间 Short circuit short delay time	0.1 ~ 1.0s 0.1 ~ 1.0s	0.3s 0.3s
功能设置3/11 Function setting 3/11	短路瞬时保护 Short circuit instantaneous protection	关闭、告警、跳闸 Close, alarm, trip	跳闸 trip
	短路瞬时阈值 Short circuit instantaneous threshold	$I_i = (2 \sim 12) \times I_R$ $I_i = (2 \sim 12) \times I_R$	10I _R 10I _R
	数据告警功能 Data alarm function	打开/关闭 (数据告警总控制位) Open/Close (Data Alarm Control Bit)	打开 Open
功能设置4/11 Function setting 4/11	过压保护功能 Overvoltage protection function	关闭、告警、跳闸 Close, alarm, trip	关闭 Close
	过压保护阈值 Overvoltage protection threshold	425V-500V, 步进1V连续可调 425V-500V, step 1V continuously adjustable	450V 450V
	过压保护延时 Overvoltage protection delay	1 ~ 10s, 步进1s连续可调 1 to 10 seconds, step 1 second continuously adjustable	3s 3s
功能设置5/11 Function setting 5/11	欠压保护功能 Undervoltage protection function	关闭、告警、跳闸 Close, alarm, trip	关闭 Close
	欠压保护阈值 Undervoltage protection threshold	300V-360V, 步进1V连续可调 300V-360V, step 1V continuously adjustable	320V 320V
	欠压保护延时 Undervoltage protection delay	1 ~ 10s, 步进1s连续可调 1 to 10 seconds, step 1 second continuously adjustable	2s 2s
功能设置6/11 Function setting 6/11	缺相保护功能 Phase loss protection function	关闭、告警、跳闸 Close, alarm, trip	关闭 Close
	缺相保护阈值 Phase loss protection threshold	250V-350V, 步进5V连续可调 250V-350V, step 5V continuously adjustable	280V 280V
	缺相保护延时 Phase loss protection delay	1 ~ 10s, 步进1s连续可调 1 to 10 seconds, step 1 second continuously adjustable	1s 1s
功能设置7/11 Function setting 7/11	Σu不平衡 Σu imbalance	关闭、告警、跳闸 Close, alarm, trip	关闭 Close
	不平衡值 Unbalanced value	5% ~ 95%、步进5%连续可调 5% to 95%, step 5% continuously adjustable	30% 30%
	保护延时 Protection delay	1 ~ 30s, 步进1s连续可调 1 to 30 seconds, step 1 second continuously adjustable	10s 10s
功能设置8/11 Function setting 8/11	Σi不平衡 Σi imbalance	关闭、告警、跳闸 Close, alarm, trip	关闭 Close
	不平衡值 Unbalanced value	5% ~ 95%、步进5%连续可调 5% to 95%, step 5% continuously adjustable	30% 30%
	保护延时 Protection delay	1 ~ 30s, 步进1s连续可调 1 to 30s, step 1 second continuously adjustable	1s 1s
功能设置9/11 Function setting 9/11	频率保护功能 Frequency protection function	关闭、告警、跳闸 Close, alarm, trip	关闭 Close
	欠频保护阈值 Underfrequency protection threshold	45.0 ~ 49.5Hz 45.0 ~ 49.5Hz	47.5Hz 47.5Hz
	过频保护阈值 Over-frequency protection threshold	50.2 ~ 65.0Hz 50.2 ~ 65.0Hz	51.5Hz 51.5Hz
功能设置10/11 Function setting 10/11	频率延时 Frequency delay	0.1 ~ 10.0s 0.1 ~ 10.0s	0.1s 0.1s
	孤岛延时 Island latency	0.5 ~ 10.0s 0.5 ~ 10.0s	1.5s 1.5s
	电压摆动 Voltage swing	20 ~ 198V 20 ~ 198V	30V 30V
功能设置11/11 Function setting 11/11	频率摆动 Frequency swing	0.1 ~ 25.0Hz 0.1 ~ 25.0Hz	0.5Hz 0.5Hz
	孤岛保护 Island protection	关闭、告警、跳闸 Close, alarm, trip	关闭 Close

说明：出厂默认值可根据用户定制。

Note: Factory defaults can be customized according to users.

3.记录查询选项

记录查询选项包括两个子菜单：1跳闸记录、2跳闸次数，如图7所示。

3.Record query options

The record query option includes two submenus:1.Trip record 2.trip times,as shown in figure 7.

The screenshot shows a menu with two main options: '记录查询' (Record query) and '时间设置' (Time setting). Under '记录查询', there are sub-options for '1 跳闸记录' (1 Trip record) and '2 跳闸次数' (2 tripping times). The '1 跳闸记录' option is selected, showing a 'Trip Log 1/10' screen. This screen displays: '跳闸类型: A相过载' (Trip Type: Phase A overload), '跳闸数值: 500A' (Trip value: 500A), and '跳闸时间: 23-03-20 10:30:30' (trip time: 23-03-20 10:30:30). The '时间设置' option shows: '23/03/18-16:16:04' (Time setting 23/03/18-16:16:04) and '复位RTC时钟: 否 (软件版本号)' (Reset RTC clock: No (Software version number)).

4.跳闸记录查询，如图8所示。

跳闸记录共有10条记录可供查询，1/10中的1表示当前共10条记录中的近1次跳闸记录。

4.The trip record query is shown in Figure 8.

There are a total of 10 trip records available for query,and the '1' in '1/10' indicates the most recent trip record among the current 10 trip records.

5.时钟设置选项

时钟设置是用于对产品年、月、日、时、分、秒进行人工手动校时用，同时也可用于查询产品的软件版本号和软件升级地址码，如图9所示。

5.Clock settings options

The clock setting is used to manually calibrate the product year, month, day, hour, minute, and second, and can also be used to query the software version number and software upgrade address code of the product, as shown in Figure 9.

6.跳闸次数查询

跳闸次数包括以下10条跳闸次数查询，如下图10所示。

6.Query the trip times

The trip times includes the following 10 queries, as shown in Figure 10 below.

The screenshot shows a menu for '跳闸次数' (Trip times) with 10 sub-options: '总跳闸: 0次' (Total trip: 0 times), '过载跳闸: 0次' (Overload trip: 0 times), '短路跳闸: 0次' (Short circuit trip: 0 times), '瞬时跳闸: 0次' (Magnetic trip: 0 times), '过压跳闸: 0次' (Over-voltage trip: 0 times), '欠压跳闸: 0次' (Under-voltage trip: 0 times), '缺相跳闸: 0次' (Phase loss trip: 0 times), '手动跳闸: 0次' (Manual trip: 0 times), and two more options for '跳闸次数' (Trip times) with '0次' (0 times).

7.系统维护选项

系统维护选项是用于对控制器的重要参数设置，该选项包括：参数校准、通信设置、记录清零三个子菜单。仅用于产品生产配置或专业人员使用。

7The System maintenance option is an important parameter setting for the controller, including parameter calibration, communication setting, and record zeroing. Only used for product production configuration or professional use.

通信设置菜单

通信设置菜单中包括通信速率、通信地址两个选项。

通信速率设置范围：1.2、2.4、4.8、9.6、19.2Kbps,默认为9.6 Kbps。

通信地址A5-A0共6位双字节参数，分12位数据设置，每位设置范围0~9。

具体对应关系从左到右设置顺序：A5 A4 A3 A2 A1 A0 = 00 00 00 00 00 01

Communication Setting Menu

The communication setting menu includes two options: communication rate and communication address.

Communication rate setting range:1.2、2.4、4.8、9.6、19.2Kbps,and the default value is 9.6 Kbps.

Communication address A5-A0 has a total of 6-bit double-byte parameters,which divided into 12-bit data setting,and each bit setting range is 0 to 9.

The specific correspondence is set in order from left to right:A5 A4 A3 A2 A1 A0 = 00 00 00 00 00 01

记录清零菜单

记录清零菜单用于产品测试完出厂前对其进行所有故障、告警、事件等记录及跳闸次数进行清零复位操作。

Record zeroing menu

The record clearing menu is used to record all faults, alarms, events, etc., and the number of trips before the product is tested and shipped to the factory

接线说明及电操功能描述 Wiring instructions and electrical operation function descriptions

- 1.此产品适用于三相三线线路中。
- 2.电动操作机构在额定工作电压的85~110%间(工作电压: AC380V), 能保证可靠操作断路器。
- 3.S1、S2、S4为控制线接入端, 信号为脉冲信号(短时接通); 表继上的触点接到S1(作为共用点)、S2(合闸)、S4(分闸)。当S1、S2通过表继上的触点接通后断路器合闸(合闸命令不需要信号一致接通或断开执行); 当S1、S4通过表继上的触点接通后断路器分闸(分闸命令不需要信号一致接通或断开执行),为自动模式。
- 4.当自动模式切换到用手动模式操作断路器合闸或分闸, 断路器能合闸或分闸。不受S1、S2、S4接通或断开信号影响。
- 5.当手动模式操作断路器闭合或断开后切换到用自动模式时, 断路器不需要按信号控制模式操作, 只有重新操作合闸信号S1、S2接通断路器合闸(合闸命令不需要信号一致接通或断开执行); 分闸S1、S4接通断路器分闸或再扣(分闸命令不需要信号一致接通或断开执行)。
- 6.当断路器故障短路跳闸或脱扣时, 操作合闸信号S1、S2接通断路器合闸(合闸命令不需要信号一致接通或断开执行); 分闸S1、S4接通断路器分闸(分闸命令不需要信号一致接通或断开执行)。在手动模式时, 不作任何操作断路器合闸、分闸。

- 1.This product is suitable for three-phase three-wire circuit.
- 2.The automatic operating mechanism is between 85 and 110% of the rated working voltage (working voltage: AC380V), which can ensure reliable operation of the circuit breaker.
- 3.S1, S2 and S4 are the access port of the control wire, and the signal is a pulse signal (short-time switched on).The contacts are connected to S1 (as a common point), S2 (turn on), and S4 (turn off). When the contacts through S1 and S2 are connected, the circuit breaker turn on (the closing command does not need to be performed by the signal to turn on or disconnect consistently); When S1 and S4 are connected through the contact, the circuit breaker turn off(the opening command does not need to be connected or disconnected by the signal in unison), which is automatic model.
- 4.When the automatic model is switched to manual model to operate the circuit breaker turn on or turn off.It is not affected by S1, S2, S4 on or off signals
- 5.When the circuit breaker turn on or turn off in manual model and switched to automatic model, the circuit breaker does not need to be operated in the signal control model, only the re-operation of the closing signal, S1 and S2 is connected ,the circuit breaker turn on (the closing command does not need to be connected or disconnected by the signal in unison); Turn off, S1 and S4 connect, the circuit breaker turn off or re-buckle (the opening command does not need to be connected or disconnected by the same signal).
- 6.When the circuit breaker is faulty, short-circuited,or tripped, Operate 'on' signals,S1 and S2 are connected , the circuit breaker turn on (the closing command does not need to be performed by the signal to be turned on or disconnected consistently); Turn off,connect S1 and S4 , the circuit breaker turn off(the opening command does not need to be performed by the signal to turn on or disconnect consistently). In manual model, the circuit breaker turn on or turn off without any operation.

接线端口使用说明 Instructions for terminal port

S1为共用点、S2为合闸、S4为分闸; A、B为RS-485, 如下图所示:

S1 is a common point, S2 is turn on, and S4 is turn off; A and B are RS-485
As shown in the figure below:

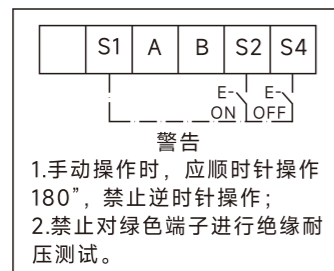

Alarm

- 1.When operating manually, it should be operated at 180°clockwise, and counterclockwise operation is prohibited.
- 2.It is forbidden to conduct insulation and withstand voltage tests on green ports.

外形及安装尺寸 Layout and installation dimensions

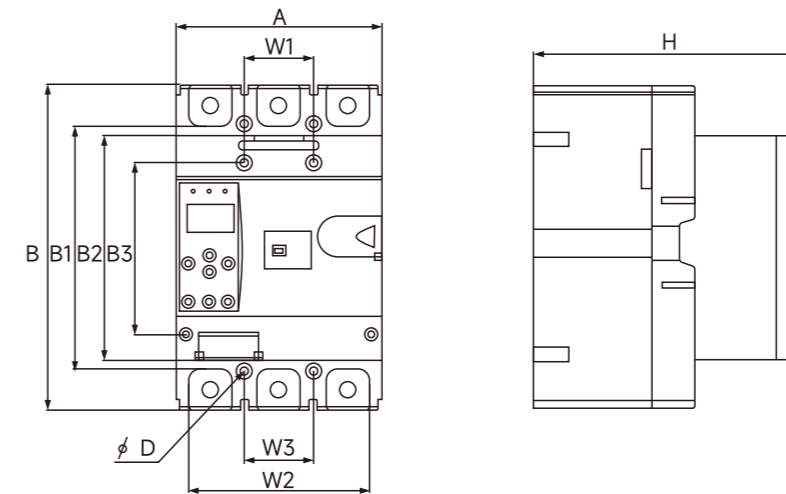

尺寸(mm) Size(mm)	型号 Model	GYCMEY3-250	GYCMEY3-400	GYCMEY3-630	GYCMEY3-800
	3级 Class3	3级 Class3	3级 Class3	3级 Class3	3级 Class3
H		136	160	160	172
A		105	140	140	210
B		165	257	257	275.5
B1		126	194	194	243
B2		114	177	177	174
B3		87.5	123.5	123.5	124
W1		35	87	87	151
W2		94.5	128.5	128.5	199
W3		35	44	44	70
D		4*Φ4.5	4*Φ7	4*Φ7	4*Φ8

接线排规格 Bar specification

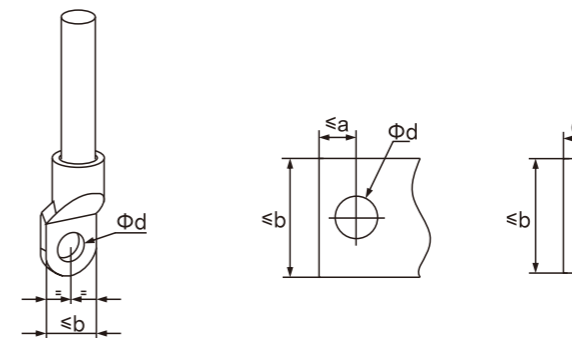

序号 No.	产品型号 Product model	接线端子宽度 Terminal width b(mm)	接线端子内孔 Wiring terminal inside holed(mm)	接线端子孔边距 Terminal hole margin a(mm)	厚度 Thicknessc(mm)
1	GYCM8EY3-250	20	Φ9	-	5.0
2	GYCM8EY3-400	28	Φ11	-	6.0
3	GYCM8EY3-630	30	Φ11	-	8.0
4	GYCM8EY3-800	40	Φ13	12	10.0

► **安装接线螺丝规格表** Install wiring screws specification table

型号 Model	名称规格 Name specification	铜排接线螺丝 Copper bar connection screws	安装螺丝 Mounting screw	备注 Remark
GYCM8EY3-250		M8*20	M4*80	
GYCM8EY3-400		M10*30	M6*65	
GYCM8EY3-630		M10*30	M6*65	
GYCM8EY3-800		M12*30	M6*40	

► **断路器所处环境温度超过+40°C由于发热所需的电流降容**

The ambient temperature of the circuit breaker exceeds +40°C due to the current reduction required for heating

型号 Model	所处环境温度 environment temperature	+40°C	+45°C	+50°C	+55°C	+60°C
GYCM8EY3-250		1In	1In	0.96In	0.88In	0.78In
GYCM8EY3-400		1In	1In	0.95In	0.88In	0.78In
GYCM8EY3-630		1In	0.98In	0.95In	0.82In	0.75In
GYCM8EY3-800		1In	0.97In	0.92In	0.80In	0.72In

► **高海拔降容** High altitude capacity reduction

海拔超过适用工作环境2000m，断路器电气性能可参照下表修正

If the altitude exceeds the applicable working environment by 2000m, the electrical performance of the circuit breaker can be corrected by referring to the following table

海拔 (m) Altitude (m)	2000	2000	2000	2000	2000	2000
工频耐压 Power frequency withstand voltage(V)	2500	2500	2250	1950	1775	1625
绝缘耐压 Insulation withstand voltage(V)	1000	1000	900	780	710	650
最大工作电压 Maximum operating voltage(V)	400	400	350	312	284	260
工作电流修正系数 Working current correction factor	1	1	0.98	0.95	0.92	0.90

► **注意事项** Matters needing attention

为了保证您的人身及用电设备的安全，断路器在投入运行前，请用户务必做到：

- (1) 在安装使用前必须认真阅读使用说明书。
- (2) 必须在正常工作条件下使用。
- (3) 在安装之前，应先确认其规格、型号是否符合要求。
- (4) 通讯接口在接线时应注意插头与接线端口匹配且方向一致，切勿接反。
- (5) 全部接线接好后，检查无误再打开电源开关。
- (6) 先进行手动调试，检查断路器的分、合、再扣动作是否正常。
- (7) 手动操作时，先将电操上活门拨到手动档，再插入操作手柄进行顺时针手动操作（禁止逆时针操作）。手动操作完毕后应把活门拨回自动档。
- (8) 通电试验前，检查电压是否相等，电源接线是否正确。
- (9) 通电试用时，首先要检查断路器，如装有欠电压脱扣器，必须开通欠电压脱扣器电源，并检查电压值是否≥85%额定电压。（注意欠电压应接主电路电源）
- (10) 通电使用时，EY3系列产品电操操作频率每小时不超过180次，EY3系列-400、630电操操作频率每小时不超过60次。
- (11) 断路器应正确安装，不应存在异常机械应力。

In order to ensure the safety of your personal and electrical equipment, before the circuit breaker is put into operation, please be sure to do:

- (1) Read the instruction manual carefully before installation and use.
- (2) Must be used under normal working conditions.
- (3) Before installation, it should be confirmed that its specifications and models meet the requirements.
- (4) When wiring the communication interface, it should be noted that the plug matches the wiring port and the direction is the same, do not reverse.
- (5) After all the cables are connected, check and then turn on the power switch.
- (6) Manual debugging is carried out first to check whether the parting, closing and rebuckle action of the circuit breaker is normal.
- (7) For manual operation, first switch the electric upper valve to the manual gear, and then insert the operating handle for clockwise manual operation (counterclockwise operation is prohibited). After manual operation, the valve should be set back to automatic.
- (8) Before the power test, check whether the voltage is equal and whether the power connection is correct.
- (9) When the power trial, first check the circuit breaker, if equipped with an undervoltage release, you must open the undervoltage release power supply, and check whether the voltage value is ≥ 85% of the rated voltage. (Note that undervoltage should be connected to the main circuit power supply)
- (10) When powered on, the electrical operating frequency of EY3 series products shall not exceed 180 times per hour, and the electrical operating frequency of EY3 series -400 and 630 shall not exceed 60 times per hour.
- (11) The circuit breaker should be installed correctly and there should be no abnormal mechanical stress.

► **故障排除方法** Troubleshooting Methods

用手动操作，试能否分合断路器，如不能分合，那应检查断路器是否滑扣，是否欠电压没有通电。无法调正，请与供方联系。

Use manual operation to test whether the circuit breaker can be closed, if it can not be closed, it should check whether the circuit breaker is slipping, whether the undervoltage is not powered on. Unable to adjust, please contact the supplier.

► **保修** Warranty

- (1) 保修期：自发货之日起算，为18个月。
- (2) 保修期内：若为本公司生产质量问题，本公司负责更换或修理；若为使用者操作不当、超过规范使用、摔落及安装过程发生损坏、天气原因及自然灾害等引起产品损坏，本公司负责有偿修理或更换。
- (3) 电操机构须定期检查（一般一年），检查各紧固部位是否有松动，动作部位是否正常，在动作处加少量润滑油脂。保修期为出厂日期起壹年，壹年内免费服务，壹年后有偿服务。
- (4) 超过保修期：在修理后能维护功能的场合下，做有偿修理，否则可作有偿更换。
- (5) 出现故障后，请与我们公司售后服务部门联系。

- (1) Warranty period: 18 months from the date of delivery.
- (2) Warranty period: If the company's production quality problems, the company is responsible for replacement or repair; If the product is damaged due to improper operation by the user, exceeding the standard use, falling and damage during installation, weather reasons and natural disasters, the company is responsible for paid repair or replacement.
- (3) The electric operation mechanism must be checked regularly (generally one year) to check whether the tightening parts are loose, whether the action part is normal, and add a small amount of lubricating oil at the action. The warranty period is one year from the factory date, free service within one year, paid service after one year.
- (4) Exceed the warranty period: in the case of maintenance function after repair, do paid repair, otherwise can be paid replacement.
- (5) After the failure, please contact our after-sales service department.